

LOW POWER VIDEO AMPLIFIER WITH Y-C MIXER

■ GENERAL DESCRIPTION

The **NJM2274** is a low power, 3V operation video amplifier with Y/C mixer and 75 ohm driver, which connect TV monitor directly. The NJM2274 has mute function, and suitable for energy save products and any low power system, which are Digital Camera, DVC and other video amplifier system.

■ PACKAGE OUTLINE



NJM2274R

■ FEATURES

- Low Operating Voltage 2.8 to 5.5V
- Internal Y/C MIX Circuit
- 12dB amplifier, 75Ω Driver Circuit
- Y-input : Clamp
C-input : Bias
- Operating Current 9.3mA typ. at V⁺=3.0V
- Operating Current at Power Save 0.9mA typ. at V⁺=3.0V
- Bipolar Technology
- Package Outline VSP8

■ BLOCK DIAGRAM

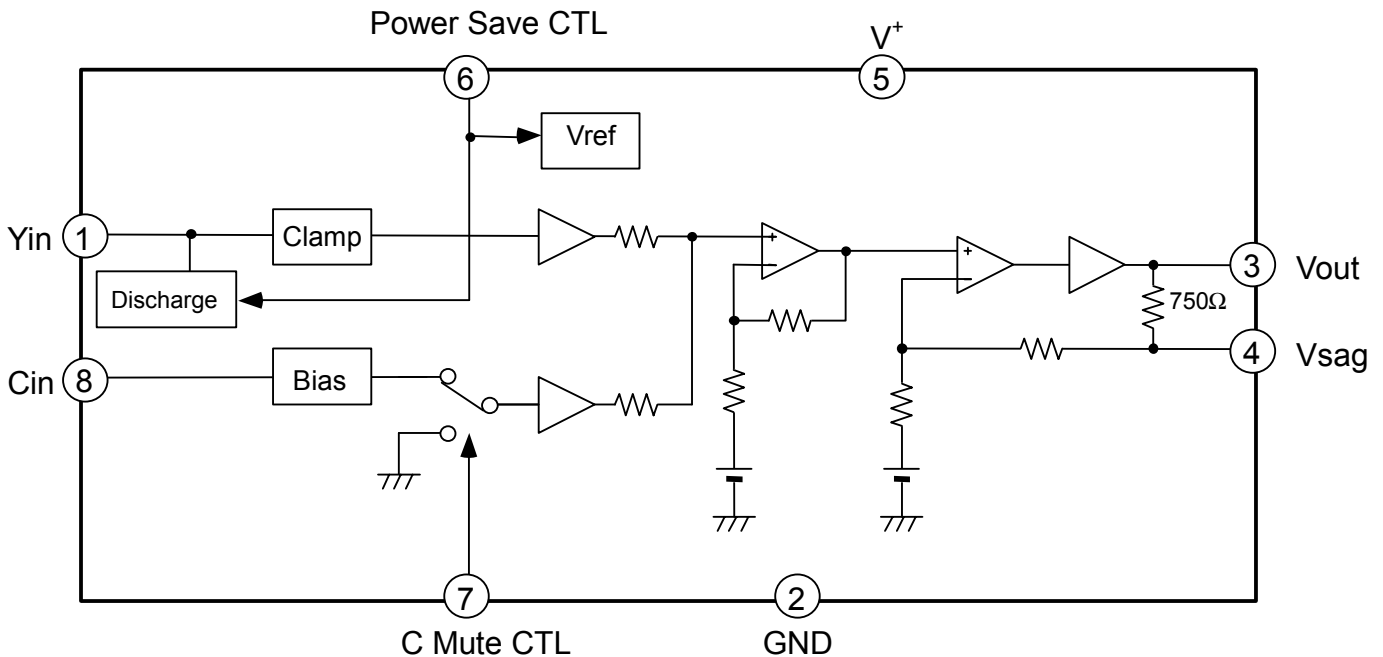

NJM2274

■ ABOSOLUTE MAXIMUM RATINGS

(Ta=25°C)

PARAMRTER	SYMBOL	RATINGS	UNIT
Supply Voltage	V ⁺	7.0	V
Power Dissipation	P _D	320	mW
Operating Temperature Range	Topr	-40 to +85	°C
Storage Temperature Range	Tstg	-40 to +125	°C

■ ELECTRICAL CHARACTERISTICS (V⁺=3.0V, Ta=25°C)

PARAMETER	SYMBOL	TEST CONDITION	MIN.	TYP.	MAX.	UNIT
Operating Voltage	Vopr		2.8	3.0	5.5	V
Operating Current	Icc	No Signal	-	9.3	14.0	mA
Operating Current (Power Save Mode)	Isave	Power Save Mode	-	0.9	1.4	mA
Maximum Output Voltage	Vom	f=1kHz, THD=1%	2.2	-	-	Vpp
Voltage Gain	Gv	Yin=100kHz, 0.5Vpp, Sine Video Signal (note)	11.9	12.4	12.9	dB
Frequency Characteristic	Gf	Yin=10MHz/100kHz, 0.5Vpp, Sine Video Signal (note)	-1.0	0	+1.0	dB
Differential Gain	DG	Yin=0.5Vpp, 10Step Video Signal	-	2.5	-	%
Differential Phase	DP	Yin=0.5Vpp, 10Step Video Signal	-	1.0	-	deg
Chroma Mute Cross talk	CT	Cin=4.43MHz, 0.1Vpp	-	-65	-	dB
S/N	SNv	Yin=0.5Vpp, 100%White Video Signal, Cin=AC gnd Wide Band 100kHz to 6MHz, R _L =75ohm	-	-60	-	dB
Second Distortion	Hv	Yin=0.5Vpp, 3.58MHz Red Field Video Signal, Cin=AC gnd R _L =75ohm	-	-40	-	dB
Input Resistance	Rcin	Chroma Input	-	20	-	kΩ
Mute Switch Change Voltage	VthMH		1.4	-	V ⁺	V
	VthML		0	-	0.6	
Power Save Switch Change Voltage	VthPH		1.4	-	V ⁺	V
	VthPL		0	-	0.6	

(note) Sine Video Signal

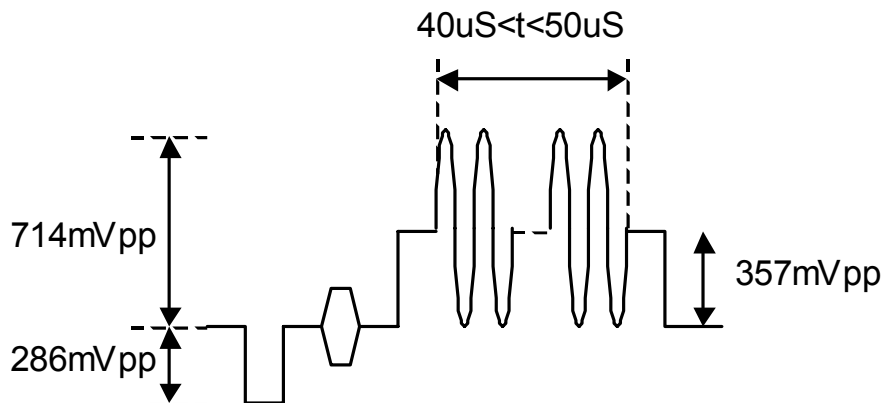

Ver.3

New Japan Radio Co., Ltd.

CONTROL TERMINAL EXPLANATION

PARAMETER	STATUS	NOTE
Chroma Mute	H	Chroma Mute: ON
	L	Chroma Mute: OFF
	OPEN	Chroma Mute: OFF
Power Save	H	Power Save: OFF
	L	Power Save: ON
	OPEN	Power Save: ON

TEST CIRCUIT

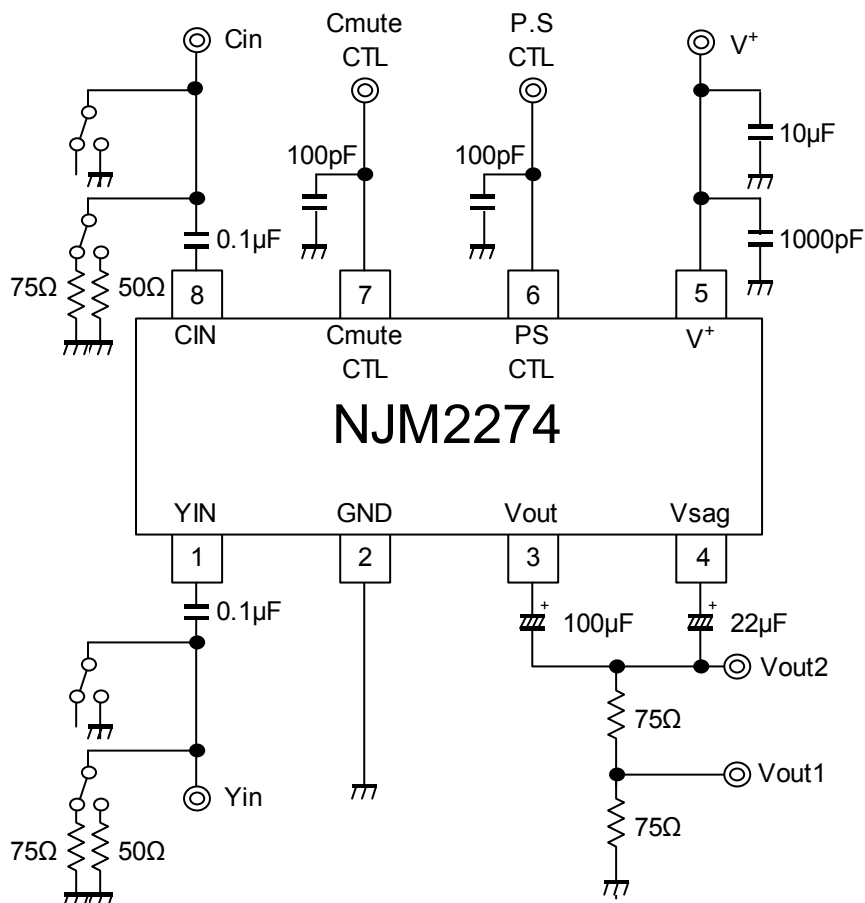

NJM2274

APPLICATION CIRCUIT

(1) Standard circuit

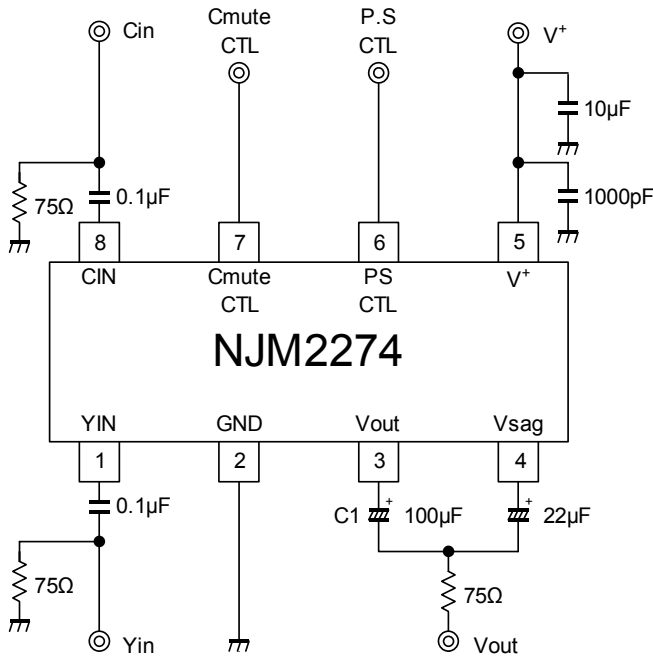

(2) SAG correction unused circuit

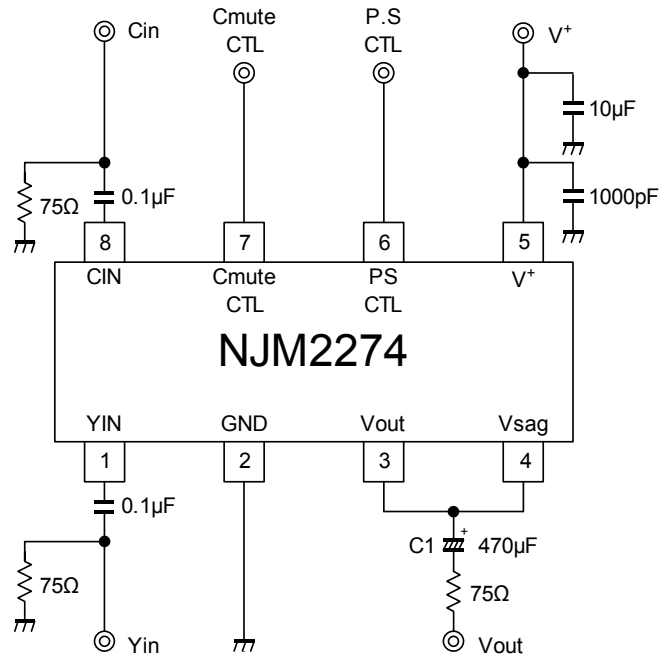

(1) Standard circuit

The SAG correction reduces output coupling capacitor values.

The capacitor of C1 (33μF) is recommended for the portable application.

However, the 33μF capacitor may deteriorate SAG, and lose synchronization by luminance fluctuation.

Adjust the C1 value, checking the waveform containing a lot of low frequency components like a bounce waveform (In case of worst condition). Change the capacitor of C1 into a large value to improve SAG.

(2) SAG correction unused circuit

Cancel the SAG correction to improve lost synchronization.

Connect the coupling capacitor after connecting the Vout pin and Vsag pin. The recommended value is 470μF or more.

(Note)

The NJM2274 can't drive two-line load of 150Ω.

TYPICAL CHARACTERISTICS

I_{cc} vs. V⁺

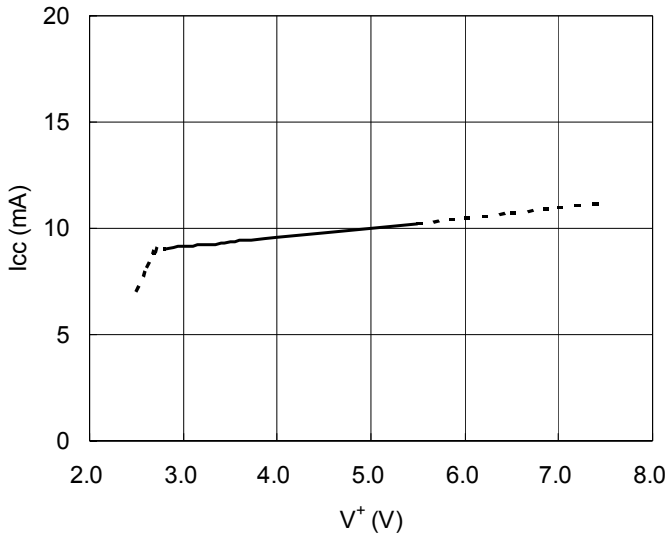

I_{save} vs. V⁺

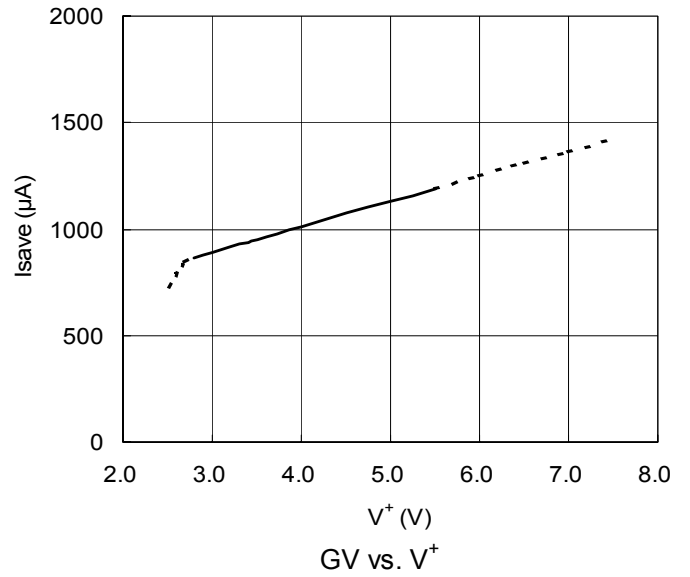

Voltage Gain vs. Frequency

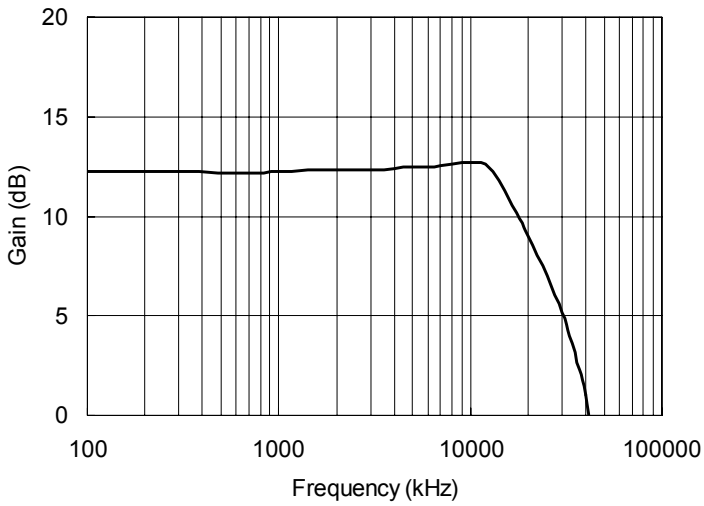

G_v vs. V⁺

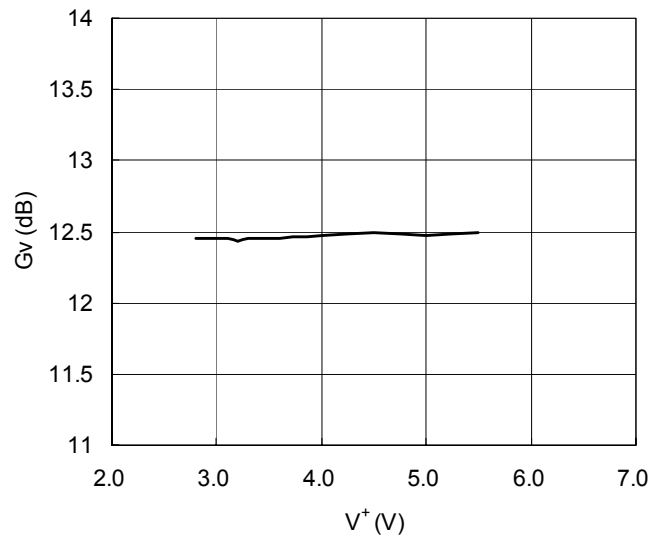

G_f vs. V⁺

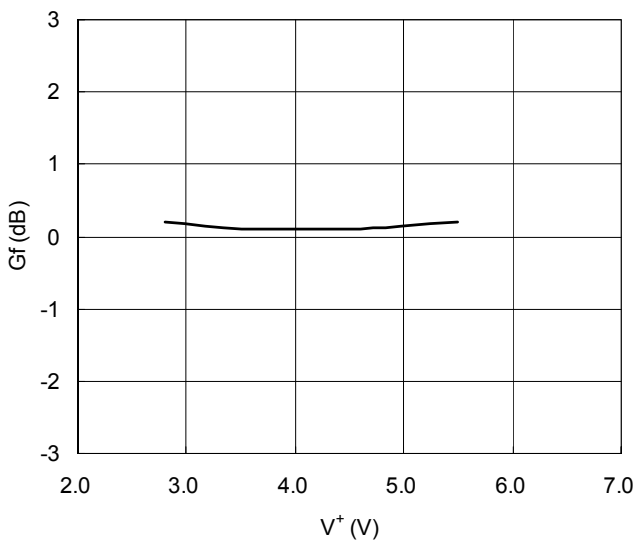

CT vs. V⁺

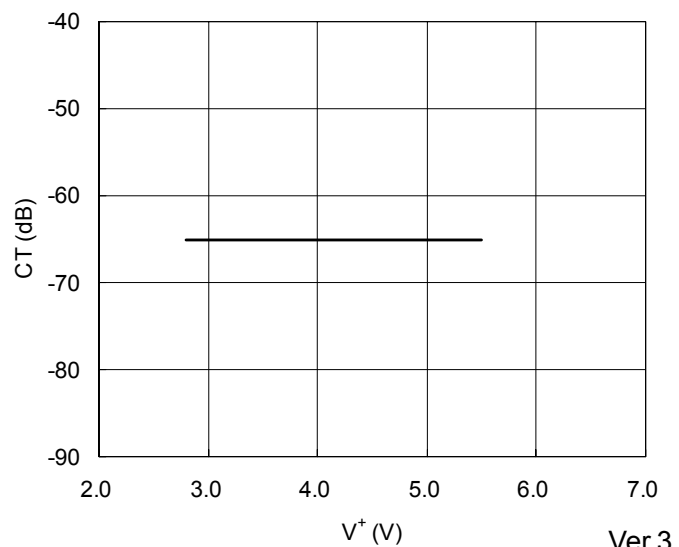

THD vs. V^+

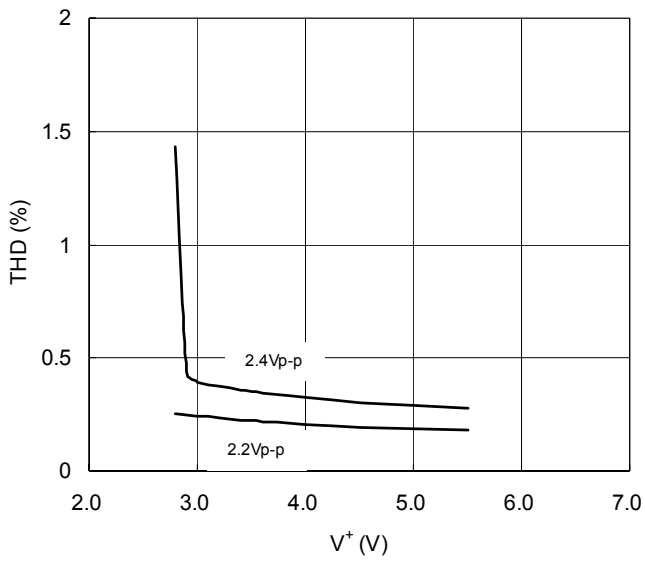

I_{cc} vs. T_a

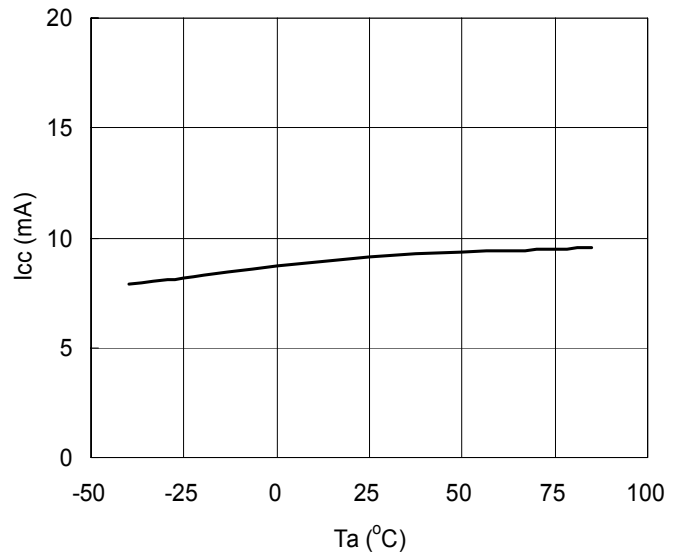

I_{save} vs T_a

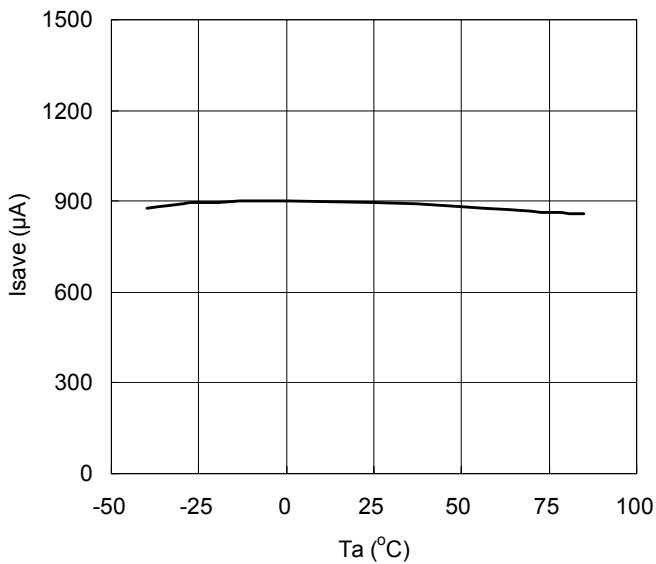

G_v vs T_a

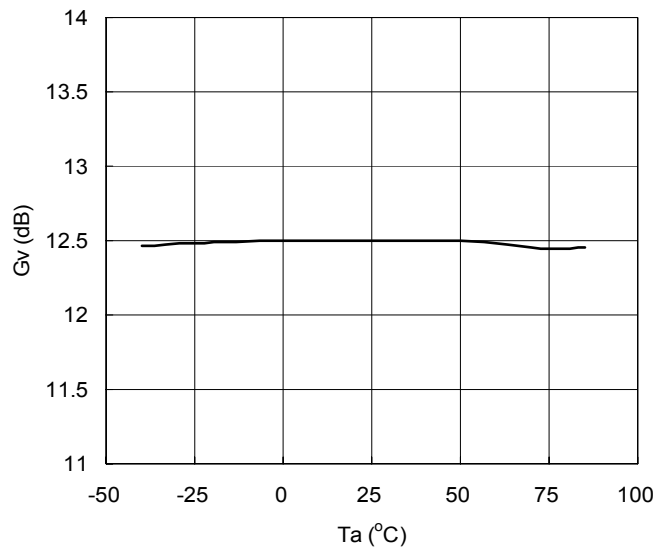

G_f vs T_a

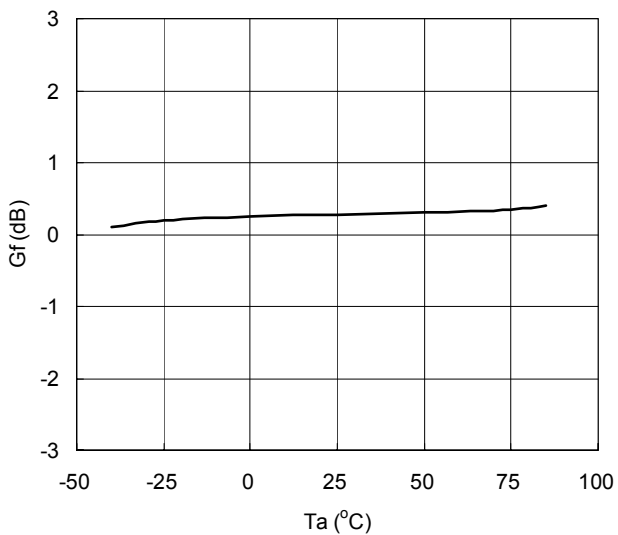

DG/ DP vs T_a

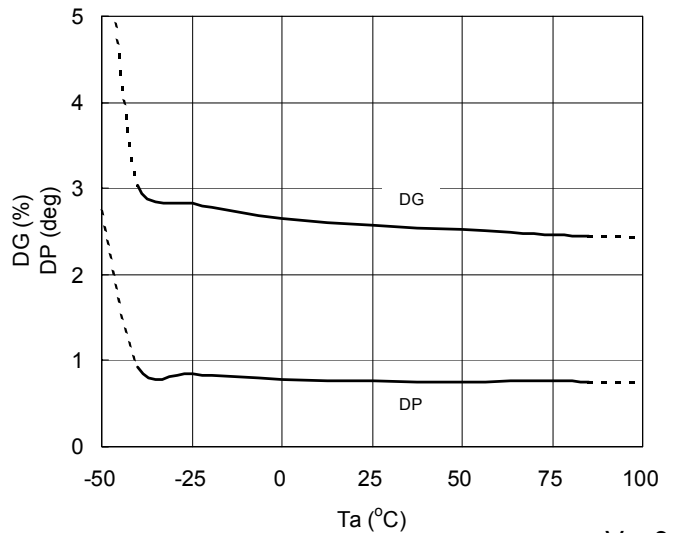

CT vs Ta

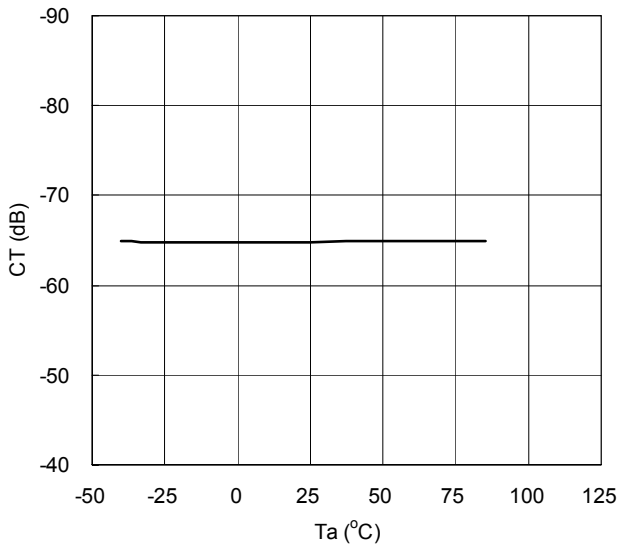

Vth vs. Ta

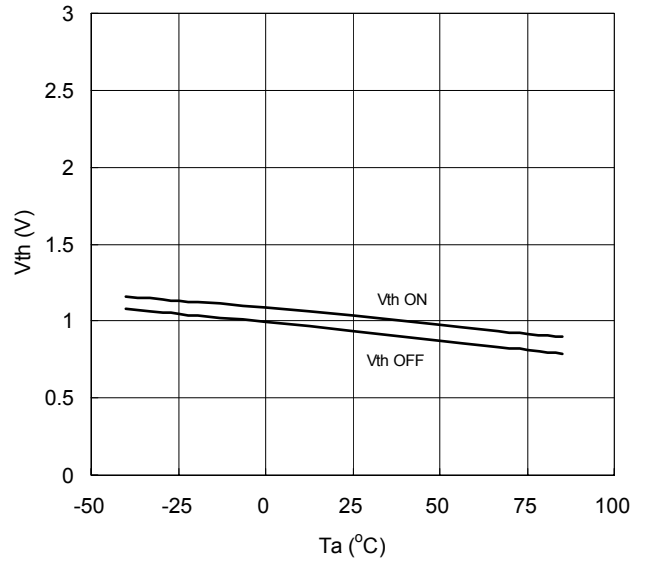

[CAUTION]

The specifications on this databook are only given for information, without any guarantee as regards either mistakes or omissions. The application circuits in this databook are described only to show representative usages of the product and not intended for the guarantee or permission of any right including the industrial rights.